

SOLAR 225 NLCV

Operating Weight: 21.000 ~ 21.300 kg

Bucket capacity (SAE): 0,5 ~ 1,28 m³

Engine Power: 110 kW (148 Hp) / 2.000 rpm



www.eurodaewoo.com

DAEWOO
Tracing the Way

Performance

This hydraulic excavator is equipped with the air-to-water intercooler engine, which has the greatest power output in its class and excellent fuel economy. It assures outstanding workability, productivity, and efficiency through the e-EPOS system, the new and improved version of EPOS System. This will assure increase in operating capacity and decrease in fuel consumption.

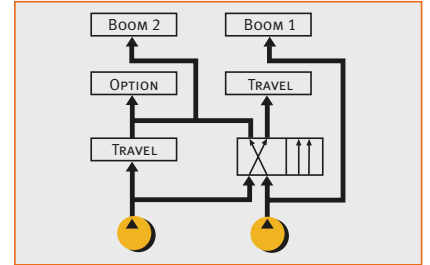
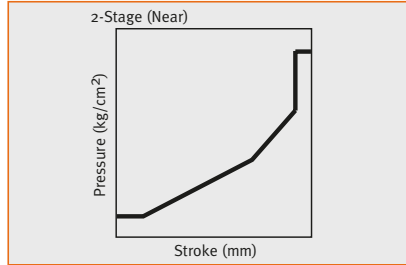

Improved manoeuvrability and control

New technologically advanced control valve and joystick valves have been installed to allow speedy, smooth and responsive control.

Advanced hydraulic circuit separates the oil flow for travel and boom function to allow precise and safe operation when handling loads during travel.

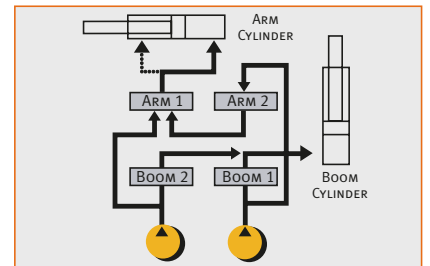

The circuits for the boom, arm, and bucket have been improved to assure smooth and confident control during combination.

Air-to-water Intercooler Engine

Greatest power output and high-efficiency engine in its class.

Environmentally friendly, Green engine

This machine is equipped with the engine meeting the U.S. EPA Tier-II Regulations and European stage-II.

Joystick grip with 3 switches

Spare switches are installed on both joystick grips to control the additional attachment.

Improved swing mechanism. (Equipped with anti-rebound valve)

Swing anti-rebound valve is installed as standard equipment, which allows the operator to stop the upper structure at the desired position.

As a result, operating efficiency has been greatly improved.

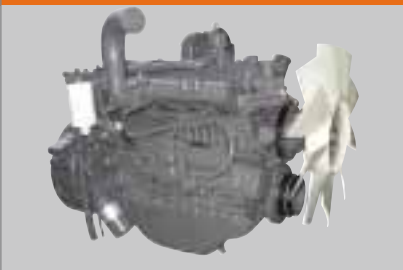

Excellent Reliability

Daewoo's world-class center for product reliability performs sophisticated testing on all completed products, to ensure they meet or exceed market standards.



Heat shield panel for turbo charger

The heat shield guard has been installed over the turbo charger to prevent the operator from inadvertently touching the hot surfaces while checking the engine area.



Emergency throttle cable

In the event of engine speed control dial malfunction, emergency throttle cable mounted in the cabin can be used to manually control engine speed.

Improved stability

The center of gravity has been lowered and optimized by the strengthened undercarriage. These have greatly improved the dynamic stability and side lifting capacity.



Rubber coated wire harness clamps

Electric wire harnesses have been mounted with rubber coated clamps to decrease vibration damage.

Rubber pipe clamps

Improved material pipe clamps have been installed. This has resulted in noise reduction, increased vibration absorption and durability characteristics as well as preventing pipe cracks.



Working Environment

Wide operator cabin space meeting the ISO Standards and expanded all-round visibility. The low-noise, low-vibration type comfortable cabin provides the operator with safe and ergonomic operating environment.



Good visibility

The enlarged right-hand glass and the minimized crosswise strut in windshield have been achieved to increase the visual range by 15% when compared to the previous machine.

Increased foot space

Instruments, controls, and accessories have been ergonomically located in the cabin and 300mm seat slide has been achieved to provide ample space for operator's feet and legs.



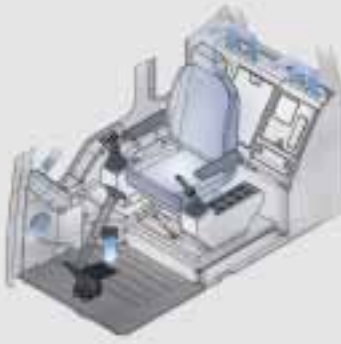

Fresh Air Type Air Conditioner

One touch selector switch for the air conditioner and heater output, featuring a multivent circulation system that allows for greater cooling / heating performance. Improved front window defroster system has been added to provide enhanced clarity and visibility during any working condition.

- Easy replaceable air filter
- Larger cool air intake vents
- Industry standard fresh air/recirculation control system incorporated
- Modular electric fan condenser compartment



Cup holder

A folding style cup holder has been installed in the cabin allowing the operator to easily store a can or cup.



12 V Spare Power Socket

This socket can be used for charging a cellular phone or powering a small 12 V DC electrical device.

Low Vibration Cab Mounting System

By using a total isolating seal design (full sealing) outside noise has been drastically reduced to the levels comparable to that in a modern car. A viscous sealed mounting system has been incorporated, and the frame, cabin and seat have been designed to absorb major and minor vibrations, resulting in a significant decrease in vibration felt by the operator.

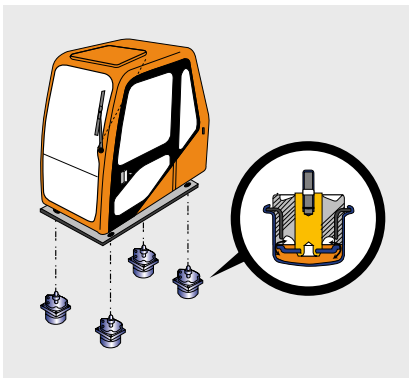

Long wind shield wiper blade

Front visibility is further improved by using the lengthened wiper blade.

Large ceiling cover

The ceiling cover can be opened to confirm the bucket operation even at the maximum excavating height.



Maintenance

Quick and easy service checks, maximizing the excavator's life expectancy.



Engine oil drain valve

The engine oil drain valve with quick coupler provides fast and environmentally sound serviceability.



Electrical control access box

Pull-out style drawer for electrical control access box allows for easy service and maintenance.



PC monitoring function (SMS)

By connecting a laptop PC to the controller (e-EPOS controller) of the machine, data such as pump pressure and engine RPM can be displayed graphically. Also other various machine status data can be stored in memory and printed out using a printer.

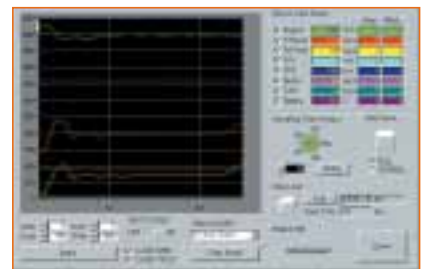

Easy radiator cleaning

The clearance between the oil cooler and radiator has been widened for easy insertion of the air nozzle during cleaning.

Water separator

The transparent glass water separator is mounted at a location easily accessible from the ground allowing easy maintenance of the fuel system.



GRAPHIC DISPLAY LCD MONITOR PANEL

The information monitor panel displays both text and symbols for easy recognition of machine status and various other data.

SIMPLIFIED OPERATION MODE SELECTION

The 3 work modes from the previous models have been reduced to digging and trenching modes for easy selection.

Digging Mode :

General Excavating, Ground Leveling, Loading Dump Truck, allows for versatility.

Trenching Mode :

trenching or excavating of side wall, operations which require heavy swing work.

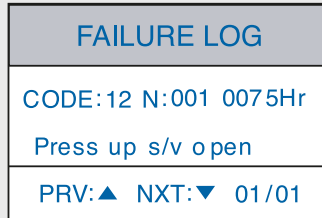

Self-diagnosis and fault history memory functions

Current faults and past faults history of the excavator control system are displayed and memorized on a real-time basis to enable correct diagnosis and quick repair.



Real-time clock with day / date

The real-time clock displays date and day in easy to read format.



Filter / oil operating hour display

The hours in use for 9 filters and oils can be displayed so that replacement intervals can be easily recognized.

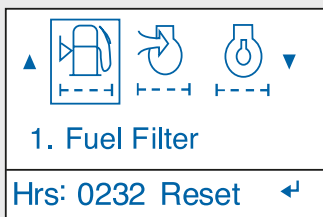

Multiple language display

The user menu can be displayed in multiple languages for the operator's convenience.



Real-time machine data display

Displays 28 different machine status data and information such as pump delivery pressure and engine RPM.

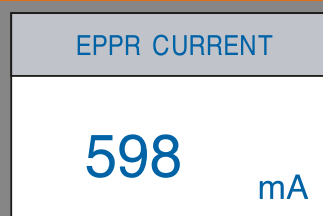

Technical Data



ENGINE

MODEL

DAEWOO DB58TIS

TYPE

Water-cooled, 4-cycle, direct injection

ASPIRATION

Turbocharged – air-to-water intercooler

NUMBER OF CYLINDERS

6

RATED FLYWHEEL HORSE POWER

DIN 6271, net 110 kW (148 Hp)
at 2.000 rpm
SAE J1349, net 110 kW (148 Hp)
at 2.000 rpm

PISTON DISPLACEMENT

5.785 cc

MAXIMUM TORQUE

61,5 kgf.m (603 Nm) at 1.500 rpm

BORE AND STROKE

102 x 118 mm

STARTING SYSTEM

24 V electric motor

BATTERIES

2 x 12 V x 100 Ah



HYDRAULIC SYSTEM

e-EPOS (Electronic Power Optimizing System) allows the operator to maximize work efficiency over a full range of operating conditions and to minimize fuel consumption.

- Hydraulic system assures fully independent and combined operations.
- Automatic 2 speed travel system for high traction force and travel speed.
- Cross-sensing and fuel saving pump system.
- Auto idle system.
- 2-Working /2-power mode selection system.
- Computer aided engine-pump control.

MAIN PUMPS

2 variable displacement axial piston pumps.

Max. oil flow 2 x 211 l/min

PILOT PUMP

Gear pump

Max. oil flow 30 l/min

SWING MOTOR

Relief valve 279 bar

MAIN RELIEF VALVES

Boom/Arm/Bucket

– Normal 324 bar

– Power Boost 343 bar

Travel circuit 324 bar



HYDRAULIC CYLINDERS

High-strength piston rods and tubes are used. Cylinder cushion mechanism is provided for all cylinders to assure shock-free operation and extend life of cylinder.

Cylinders	Q'ty	Bore x Rod dia. x Stroke
Boom	2	120 x 85 x 1.245 mm
Arm	1	135 x 95 x 1.538 mm
Bucket	1	120 x 80 x 1.050 mm



SUPER-STRUCTURE REVOLVING FRAME

A deep, full-reinforced box section. Heavy-gauge steel plates used for ruggedness.



2 TRAVEL PEDALS WITH LEVERS

Pilot pressure control type. Independent drive at each track allows counter-rotation of the tracks. Levers are detachable.



CONTROLS 2 IMPLEMENT LEVERS

Pilot pressure control type. Right lever is boom and bucket control, left lever for swing and arm control.



OPERATOR'S CAB

A roomy, independent, shock and noise-free operator's cab, 4 side safety glass windows give all-round visibility. Front window slides up and stores in the roof and side window can be opened for ventilation. Fully adjustable suspension seat. Air conditioner. ISO standard cab.

NOISE LEVELS (DYNAMIC VALUE)

LwA external noise:

– Guaranteed Sound Power Level
105 dB (A) (95/27/EEC)

– Measured Sound Power Level
103 dB (A) (ISO6396)

LpA operator noise:

74 dB (A) (ISO6396)

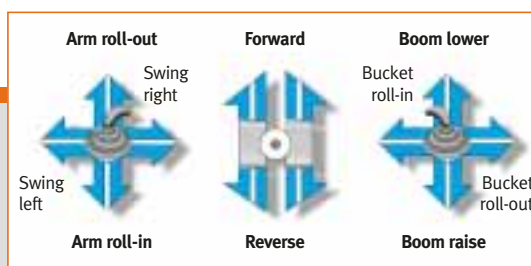



SWING MECHANISM

High-torque, axial piston motor with planetary reduction gear bathed in oil. Swing circle is singlerow, shear type ball bearing with induction-hardened internal gear. Internal gear and pinion gear immersed in lubricant. Swing parking brake is spring-set, hydraulic-released disc type. A two position swing lock secures the super-structure for transportation.

SWING SPEED

0 to 12,1 rpm

REAR SWING RADIUS

2.750 mm



DRIVE

Each track is driven by an independent, high-torque, axial piston motor through planetary reduction gear. Two levers or foot pedal control provide smooth travel or counter-rotation upon demand.

TRAVEL SPEED

5,5/3,1 km/h

MAXIMUM TRACTIVE FORCE

Force 18.800 kgf

Gradeability 35° (70%) continuous



UNDERCARRIAGE

Tractor type undercarriage. Heavy-duty track frame, all welded stress-relieved structure. Top grade materials are used for toughness. Side frames are welded, securely and rigidly, to the track frame.

Lifetime-lubricated track rollers, idlers and sprockets with floating seals. Track shoes of induction-hardened rolled alloy with triple grousers. Specially heat-treated connecting pins. Hydraulic track adjusters with shock-absorbing recoil springs.

NUMBER OF ROLLERS AND SHOES

(EACH SIDE) GROUND CONTACT AREA

Upper rollers 2

(STANDARD SHOE)

Lower rollers 9

Track shoes 49

Overall track length 4.440 mm



BRAKE

Two oil disc brake on final drive input shafts. Parking brake is spring-set, hydraulic-released disc type.



WEIGHT

Equipped with 5,2 m boom, 2,4 m arm, and 0,93 m³ (SAE heaped) bucket and 600 mm shoes.

SHOE TYPE	Shoe Width	Operating weight	Ground pressure
Triple grouser	500 mm	21.000 kg	0,53 kgf/cm ²
	600 mm	21.300 kg	0,45 kgf/cm ²



SERVICE REFILL CAPACITIES (liters)

Fuel tank	350
Cooling system	42
LUBRICATION	
Engine oil	19
Swing drive (each)	5
Final drive (each)	5,4
Hydraulic tank	214



BUCKETS

CAPACITY		WIDTH		WEIGHT	
SAE, heaped	CECE, heaped	Without side cutters	With side cutters		
0,93 m ³	0,8 m ³	1.180 mm	1.290 mm	730 kg	
0,5 m ³	0,45 m ³	688 mm	778 mm	500 kg	
0,81 m ³	0,7 m ³	1.058 mm	1.168 mm	690 kg	
1,05 m ³	0,9 m ³	1.302 mm	1.412 mm	790 kg	
1,17 m ³	1,0 m ³	1.428 mm	1.538 mm	830 kg	

A. Suitable for materials with density of 2.000 kg/m³ or less

B. Suitable for materials with density of 1.600 kg/m³ or less

C. Suitable for materials with density of 1.100 kg/m³ or less

Dimensions & Working Ranges

DIMENSIONS

A	Overall width of upper structure	2.490 mm
B	Overall width of cab	960 mm
C	Overall height of cab	3.010 mm
D	Tail swing radius	2.750 mm
E	Overall height of boom	
	Arm length (2,4 m)	3.280 mm
	Arm length (2,0 m)	3.270 mm
F	Clearance under counterweight	1.115 mm
G	Ground clearance	470 mm
H	Tumbler distance	3.645 mm
I	Track length	4.440 mm
J	Track gauge	1.990 mm
K	Track shoe width	500 mm
L	Overall length	
	Arm length (2,4 m)	9.030 mm
	Arm length (2,0 m)	9.160 mm
M	Overall track width	2.490 mm

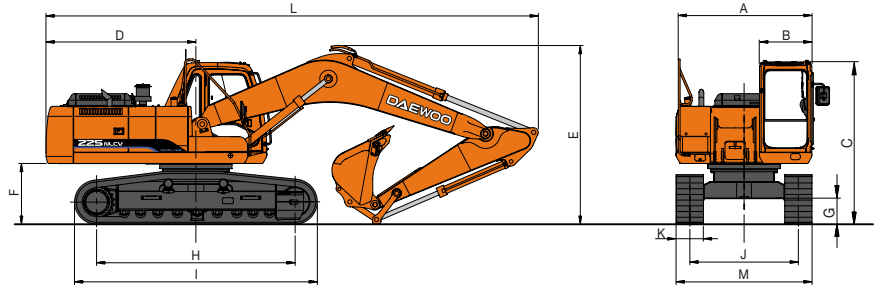

WORKING RANGES

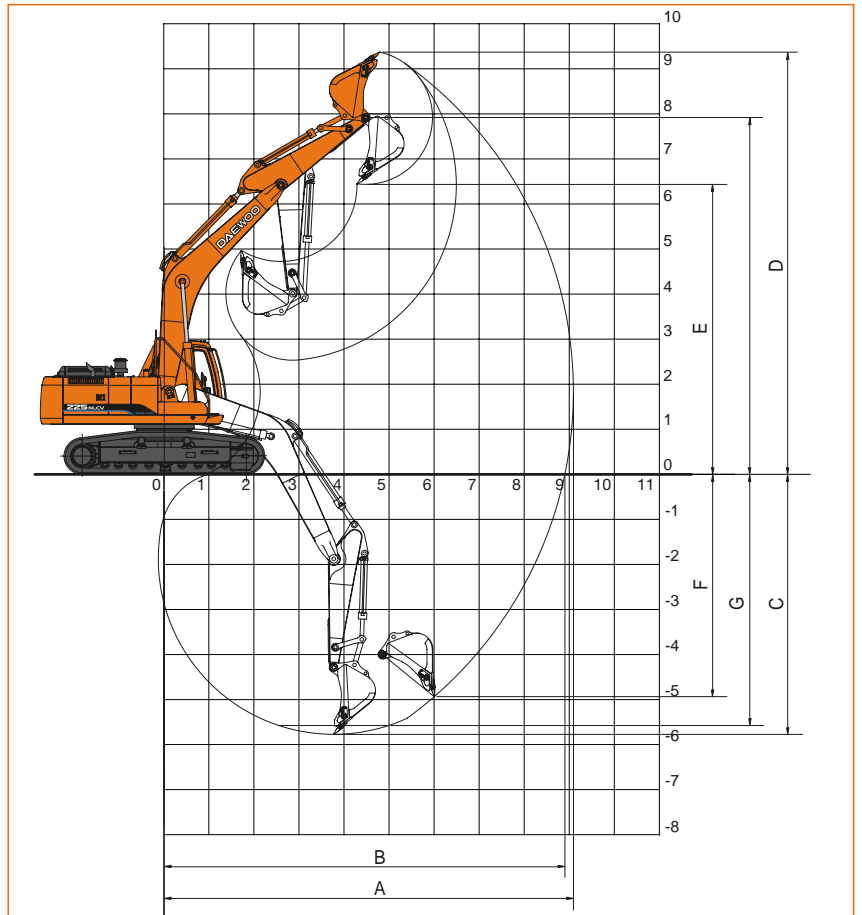

DIGGING FORCES (ISO)

		2,4 m	2,0 m
Bucket digging force *	kgf	14.700	14.700
	kN	144	144
Arm digging force *	kgf	11.900	14.900
	kN	117	146

* At power boost

Boom length (5,2 m)

Arm length 2.400 mm 2.000 mm

A.	Max. digging reach	9.080 mm	8.570 mm
B.	Max. digging reach at ground level	8.890 mm	8.360 mm
C.	Max. digging depth	5.770 mm	5.370 mm
D.	Max. digging height	9.370 mm	8.720 mm
E.	Max. dumping height	6.430 mm	5.880 mm
F.	Max. vertical wall digging depth	5.650 mm	4.670 mm
G.	Max. digging depth (8' level)	5.570 mm	5.120 mm

Lifting Capacities

STANDARD

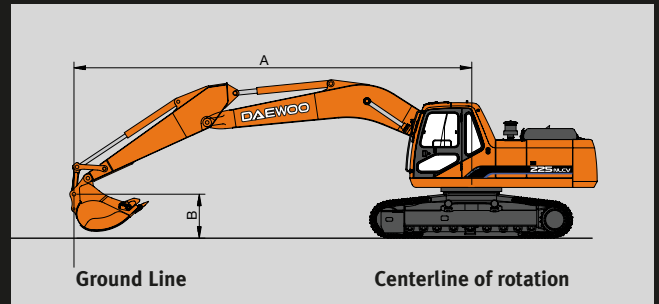

A(m)	2		3		4		5		6		7		8		Max. Reach		
	□	□	□	□	□	□	□	□	□	□	□	□	□	□	□	□	A(m)
Boom : 5,2 m — Arm : 2,0 m — Bucket : SAE 1,05 m³ (CECE 0,9 m³) — Shoe : 500 mm																	
B(m)																	
7							*5,33	5,21									*5,33 5,21 5,03
6							*5,27	3,97									*5,27 3,97 5,90
5							*5,69	5,18	*5,37	3,82							*5,30 3,33 6,49
4					*7,44	7,14	*6,35	5,02	*5,71	3,74							*5,38 2,96 6,89
3					*8,91	6,77	*7,15	4,83	*6,15	3,64	5,55	2,83					5,39 2,75 7,12
2					*10,21	6,44	*7,91	4,65	*6,61	3,53	5,48	2,77					5,22 2,64 7,21
1					*10,99	6,23	*8,47	4,50	6,92	3,44	5,42	2,72					5,24 2,63 7,16
0			*9,95	9,64	*11,20	6,13	*8,74	4,42	6,85	3,38							5,44 2,72 6,96
-1	*9,10	*9,10	*14,19	9,69	*10,94	6,11	*8,66	4,38	6,82	3,36							5,89 2,93 6,60
-2	*13,68	*13,68	*13,01	9,79	*10,23	6,15	*8,17	4,40	*6,53	3,39							*6,45 3,34 6,05
-3	*14,26	*14,26	*11,23	9,95	*8,95	6,25	*7,08	4,48									*6,60 4,17 5,26
-4			*8,42	*8,42	*6,63	6,45											*6,48 6,26 4,08



OPTION

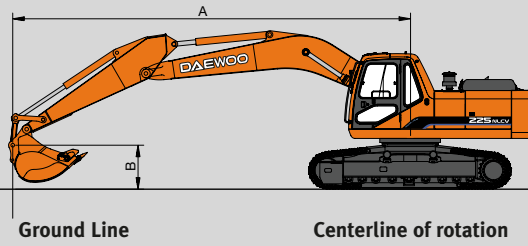

Unit : 1.000 kg

A(m)	2		3		4		5		6		7		8		Max. Reach		A(m)		
B(m)	o	□	o	□	o	□	o	□	o	□	o	□	o	□	o	□	A(m)		
Boom : 5,2 m — Arm : 2,4 m — Bucket : SAE 0,93 m³ (CECE 0,8 m³) — Shoe : 600 mm																			
7																	*3,95	*3,95	5,91
6									*4,87	4,01							*3,83	3,33	6,66
5									*5,05	3,97	*4,70	3,03					*3,82	2,89	7,19
4							*5,96	5,19	*5,43	3,88	*5,11	3,00					*3,89	2,62	7,55
3			*11,49	11,01	*8,33	7,02	*6,80	5,00	*5,92	3,77	*5,37	2,94					*4,04	2,46	7,76
2			*8,24	*8,24	*9,76	6,68	*7,64	4,80	*6,43	3,65	5,62	2,87					*4,27	2,38	7,84
1			*6,79	*6,79	*10,76	6,42	*8,31	4,64	*6,85	3,55	5,56	2,81					*4,60	2,37	7,79
0			*8,41	*8,41	*11,21	6,29	*8,71	4,54	7,00	3,48	5,51	2,77					4,85	2,44	7,61
-1	*6,87	*6,87	*11,27	9,84	*11,16	6,23	*8,77	4,48	6,96	3,44	5,49	2,75					5,17	2,60	7,28
-2	*10,26	*10,26	*13,85	9,91	*10,66	6,25	*8,46	4,48	*6,85	3,44							*5,70	2,89	6,79
-3	*14,34	*14,34	*12,29	10,04	*9,62	6,32	*7,65	4,53	*5,95	3,50							*5,76	3,42	6,10
-4	*12,78	*12,78	*9,90	*9,90	*7,80	6,46	*5,90	4,66									*5,64	4,51	5,12
Boom : 5,2 m — Arm : 2,0 m — Bucket : SAE 1,05 m³ (CECE 0,9 m³) — Shoe : 600 mm																			
7							*5,33	5,27									*5,33	5,27	5,03
6							*5,27	4,02									*5,27	4,02	5,90
5							*5,69	5,24	*5,37	3,87							*5,30	3,38	6,49
4					*7,44	7,22	*6,35	5,08	*5,71	3,79							*5,38	3,00	6,89
3					*8,91	6,85	*7,15	4,89	*6,15	3,69	*5,55	2,87					5,47	2,79	7,12
2					*10,21	6,52	*7,91	4,71	*6,61	3,58	5,56	2,81					5,31	2,68	7,21
1					*10,99	6,31	*8,47	4,56	*6,96	3,49	5,51	2,76					5,32	2,67	7,16
0			*9,95	9,77	*11,20	6,21	*8,74	4,48	6,95	3,43							5,52	2,76	6,96
-1	*9,10	*9,10	*14,19	9,82	*10,94	6,19	*8,66	4,45	6,93	3,41							5,98	2,97	6,60
-2	*13,68	*13,68	*13,01	9,92	*10,23	6,23	*8,17	4,47	*6,53	3,44							*6,45	3,39	6,05
-3	*14,26	*14,26	*11,23	10,08	*8,95	6,34	*7,08	4,55									*6,60	4,23	5,26
-4			*8,42	*8,42	*6,63	6,53											*6,48	6,34	4,08

Note 1. Ratings are based on SAE J1097
 2. Load point is the hook on the back of the bucket
 3. * = Rated loads are based on hydraulic capacity
 4. Rated loads do not exceed 87% of hydraulic capacity or 75% of tipping capacity

o : Rating over front
 □ : Rating over side or 360 degree
 o : Ground

Standard & Optional Equipment

STANDARD EQUIPMENT

HYDRAULIC SYSTEM

- Boom and arm flow regeneration
- Boom and arm holding valves
- Swing anti-rebound valves
- Spare ports (valve)
- One-touch power boost
- Piping for hammer (one way)

CABIN & INTERIOR

- Viscous cab mounts
- All weather sound suppressed type cab
- Air conditioner
- Adjustable suspension seat with head rest and adjustable arm rest
- Pull-up type front window and removable lower front window
- Room light
- Intermittent windshield wiper
- Cigarette lighter and ashtray
- Cup holder
- Hot & cool box
- Graphic display monitor
- Fuel control dial
- AM/FM Radio and cassette player
- Remote radio ON/OFF switch
- 12 V spare power socket
- Serial communication port for laptop PC interface
- Joystick lever with 3 switches

SAFETY

- Large handrails and step
- Punched metal anti-slip plates
- Seat belt
- Hydraulic safety lock lever
- Safety glass
- Hammer for emergency escape
- Right and left rearview mirrors
- Boom and arm hose rupture protection valve

OTHERS

- Double element air cleaner
- Pre-cleaner
- Water separator
- Dust screen for radiator
- Engine overheat prevention system
- Engine restart prevention system
- Self-diagnostic system
- Alternator (24 V, 50 A)
- Electric horn
- Halogen working lights (frame mounted 2, boom mounted 2)
- Electric fuel supply pump
- Hydraulic track adjuster
- Track guards

OPTIONAL EQUIPMENT

SAFETY

- Overload warning device
- Cabin Top/Front guard (FOGS standard)
- Travel alarm
- Travel & swing alarm
- Rotating beacon

CABIN & INTERIOR

- Sunvisor
- Sun roof

OTHERS

- Piping for rotation
- Double fuel filter
- Additional work lights on the cabin
 - 2 front lamps
 - 4 front and 2 rear lamps
- Large capacity alternator (24 V, 80 A)

Boom and arm hose rupture protection valve



Sunvisor



Additional work lights on the cabin



Electric fuel supply pump



Rotating beacon



SOLAR 225 NLCV

Seoul Office

9th Floor, Daewoo Heavy Industries & Machinery Ltd. Bldg.
14-34, Youido-dong, Youngdungpo-gu
150-010, Seoul Korea
Mail: C. P. O Box 7955 Seoul, Korea
Tel. +82 2 2167-3114 Fax +82 2 785-2677
Website: www.dhiltltd.co.kr

Euro Daewoo S. A.

1A Rue Achille Degrâce,
7080 Frameries, Belgium
Tel. +32 65 61 32 30 Fax +32 65 67 73 38

Euro Daewoo France

2/4, Rue Pavlov, Z.I. des Bruyères
78190 Trappes, France
Tel. +33 1 30 16 21 41 Fax +33 1 30 16 21 44

Euro Daewoo UK

Daewoo House Unit 6.3 Nantgarw Park Cardiff
CF4 7QU, U.K.
Tel. +44 1443 842273 Fax +44 1443 841933

Daewoo Maschinen Vertriebs GmbH

Hans-Böckler-Str. 27-29
40764 Langenfeld, Germany
Tel. +49 2173 8509 18 Fax +49 2173 8509 40
Website: www.daewoomaschinen.de



The illustrations do not necessarily show the product in standard version. All products and equipments are not available in all markets. Materials and specifications are subjects to change without prior notice.

S225NLCV_UK_02/05 • Design by Size Communication (Belgium)

www.eurodaewoo.com

DAEWOO
Tracing the Way