

SOLAR 140WV RAILWAY

Operating Weight: 18.270 kg

Engine Power: 96 kW (128 Hp) / 2.200 rpm

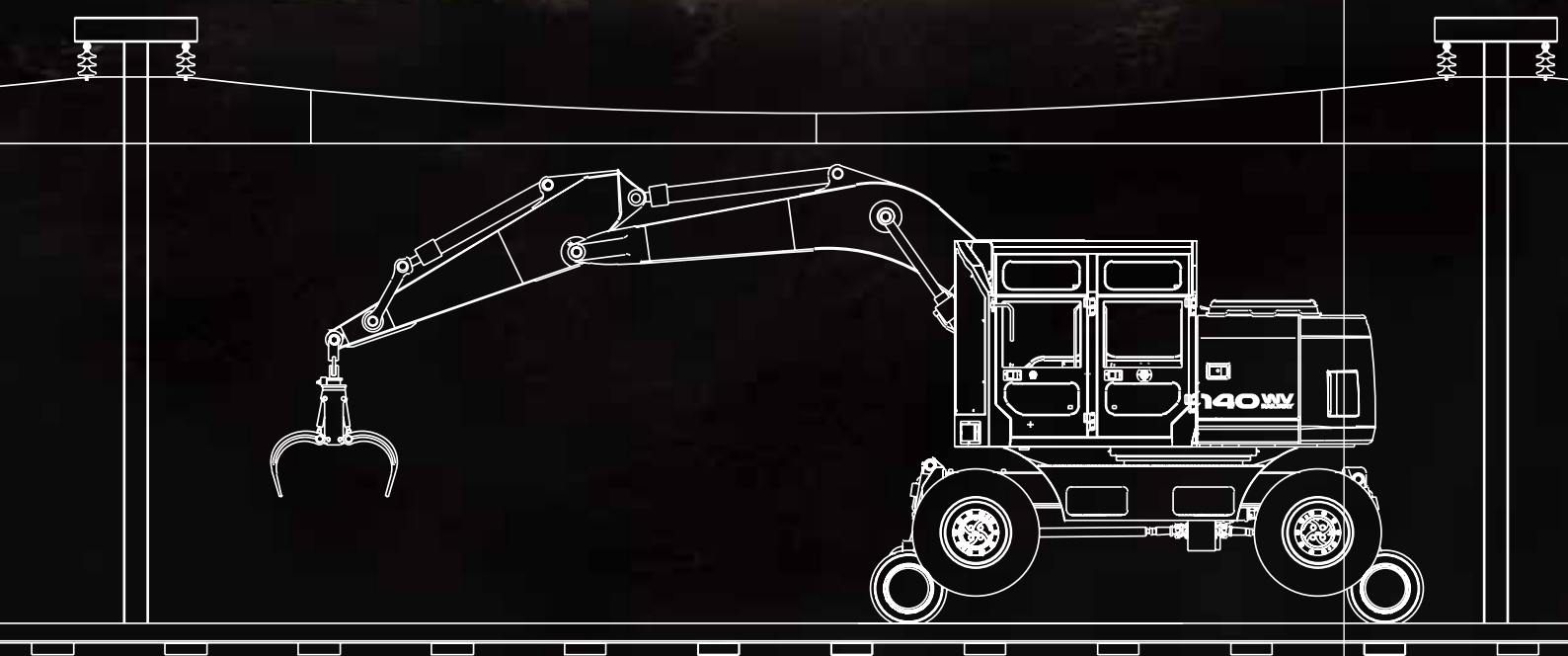

www.eurodaewoo.com

DAEWOO

Technical Data



ENGINE

MODEL

DAEWOO DB58TIS

TYPE

Water-cooled, 4-cycle, 6-cylinder in line, direct injection chamber type diesel engine.

RATED FLYWHEEL HORSE POWER

DIN 6271, net 96 kW (130 Ps)
at 2.200 rpm
SAE J1349, net 96 kW (128 Hp)
at 2.200 rpm

PISTON DISPLACEMENT

5.785 cc

MAXIMUM TORQUE

50 kgf.m (490 Nm) at 1.600 rpm

BORE AND STROKE

102 x 118 mm

STARTING SYSTEM

24 V electric motor

BATTERIES

2 x 12 V x 150 Ah

AUTO-IDLE SYSTEM

Engine rpm is reduced automatically to the low idle rpm after a lapse of approx. 4 seconds with all control levers in neutral position, thus saving energy and reducing noise.



HYDRAULIC SYSTEM

Daewoo's e-EPOS (Electronic Power Optimizing System) can achieve maximum job efficiency and reduce fuel consumption.

- 2-power mode working system
- 2-Working mode selection system
- Computer aided engine pump control
- Hydraulic system assures fully independent and combined operations
- Cross-sensing and fuel saving pump system
- Auto idle system
- 2 speed travel system for high traction force and travel speed
- Travel motor brake torque-up system
- Cruise travel system

MAIN PUMPS

2 variable displacement axial piston pumps.

Max. oil flow 2 x 162 l/min

PILOT PUMP

Gear pump

Max. oil flow 22 l/min

Pressure setting 39 bar

BRAKE PUMP

Gear pump

Max. oil flow 14,3 l/min

Pressure setting 157 bar

STEERING PUMP

Gear pump

Max. oil flow 28 l/min

Pressure setting 167 bar

MAIN RELIEF VALVES

Boom/Arm/Bucket 343 bar

Travel circuit 343 bar

OVERLOAD RELIEF VALVES

Boom circuit 353 bar

Arm circuit 353 bar

Bucket circuit 353 bar

SWING MOTOR RELIEF VALVE 265 bar



HYDRAULIC CYLINDERS

High-strength piston rods and tubes are used. Cylinder cushion mechanism is provided for boom, articulated boom. Arm and bucket cylinders to assure shock-free operation and extend life of cylinder.

MONO BOOM

Cylinders	Q'ty	Bore x Rod dia. x Stroke
Boom	2	110 x 75 x 1.030 mm
Arm	1	110 x 75 x 1.085 mm
Bucket	1	95 x 65 x 885 mm



SWING MECHANISM

High-torque, axial piston motor with planetary reduction gear bathed in oil. Swing circle is a single-row, shear type ball bearing with induction-hardened internal gear. Internal gear and pinion immersed in lubricant. Swing reactionless valve is inter-nally attached. Spring applied hydraulically released parking brake.

A swing lock clamps the superstructure for transportation.



DRIVE

Fully hydrostatic driven, 2 speed power shift transmission, variable displacement, high torque, axial piston motor, foot pedal controls provide smooth travel, hub reduction type front steering axle and rear rigid axle.

TRAVEL SPEED (ROAD)

20 km/h

TRAVEL SPEED (RAIL ROAD)

27 km/h

Standard & Optional Equipment

STANDARD EQUIPMENT

HYDRAULIC SYSTEM

- Boom and arm flow regeneration
- Boom and arm holding valves
- Swing anti-rebound valves
- Spare ports (valve)
- One-touch power boost
- Piping for hammer (one way)
- Piping for grabs
- Piping for rotating

CABIN & INTERIOR

- Viscous cab mounts
- All weather sound suppressed type cab
- Air conditioner
- Pull-up type front window and removable lower front window
- Room light
- Intermittent windshield wiper
- Cigarette lighter and ashtray
- Hot & cool box
- Graphic display monitor
- Fuel control dial
- AM/FM Radio and cassette player
- Remote radio ON/OFF switch
- 12 V spare power socket
- 2 operators cabin
- 2 roofs system
 - working
 - transportation
- Serial communication port for laptop PC interface
- Joystick lever with 3 switches

SAFETY

- Large handrails and step
- Punched metal anti-slip plates
- Seat belt
- Hydraulic safety lock lever
- Safety glass
- Hammer for emergency escape
- Right and left rearview mirrors
- Boom and arm hose rupture protection valve
- Overload warning device
- Height limiter system
- Area limiter system (Hydraulic and mechanical)
- Air horn (125 dB)
- Electrical brake down pump
- Emergency stop function
- Battery monitor
- Additional lamps
- Rod tie towing
- Rotative beacon

OTHERS

- Double element air cleaner
- Pre-cleaner
- Water separator
- Dust screen for radiator
- Engine overheat prevention system
- Engine restart prevention system
- Self-diagnostic system
- Alternator (24 V, 80 A)
- Electric horn
- Halogen working lights (frame mounted 2, boom mounted 3)
- Electric fuel supply pump
- Second tool box

WORK AREA IN GAUGE

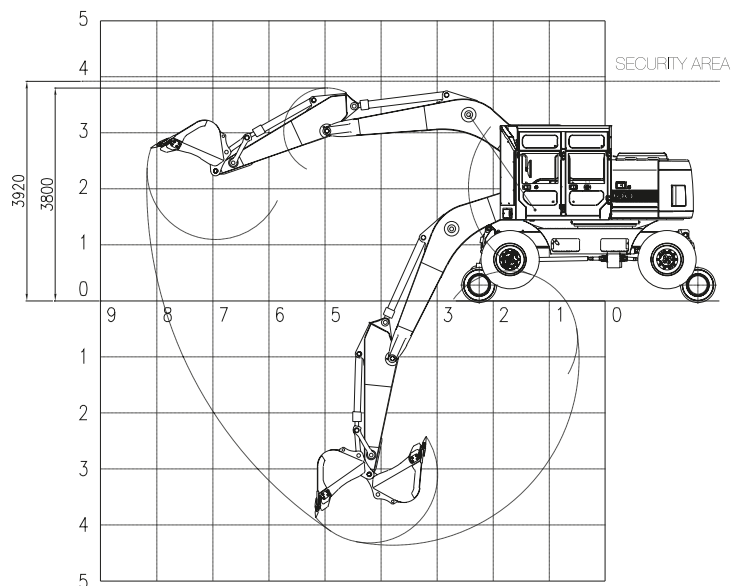

Operational data

STANDARD CONFIGURATION: 4,3 M BOOM, 2,1 M ARM

DIMENSIONS & SPECIFICATIONS

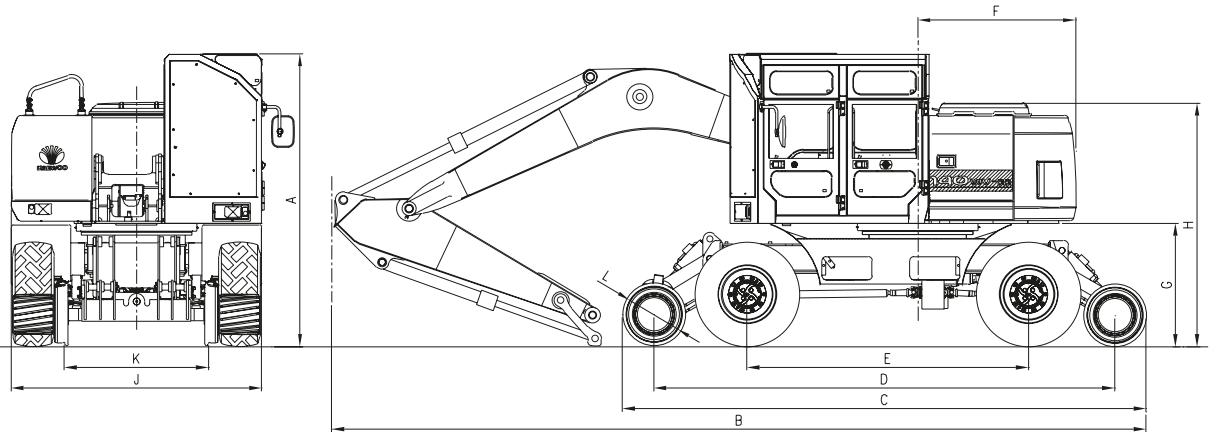

Dimensions			
Overall Transport Height	A	mm	2.917
Overall Length	B	mm	8.100
Overall Length (without Front)	C	mm	5.207,5
Length between rail road axle	D	mm	4.583,5
Length between wheels axle	E	mm	2.800
Tail Swing Radius	F	mm	1.570
Clearance under counterweight	G	mm	1.229
Overall height of engine bonnet	H	mm	2.424
Overall tire width with fender	J	mm	2.490
Length inside rail dimation	K	mm	1.435
Rail road axle diameter	L	mm	560UIC
Specifications			
Operating Weight (without Tool)		kg	18.200
Max. Reach at Ground Level (Pin Arm)		mm	8.180
Max. Height (Pin Arm)		mm	7.105
Working Capacity		kg	450
Cabin 2 operators			

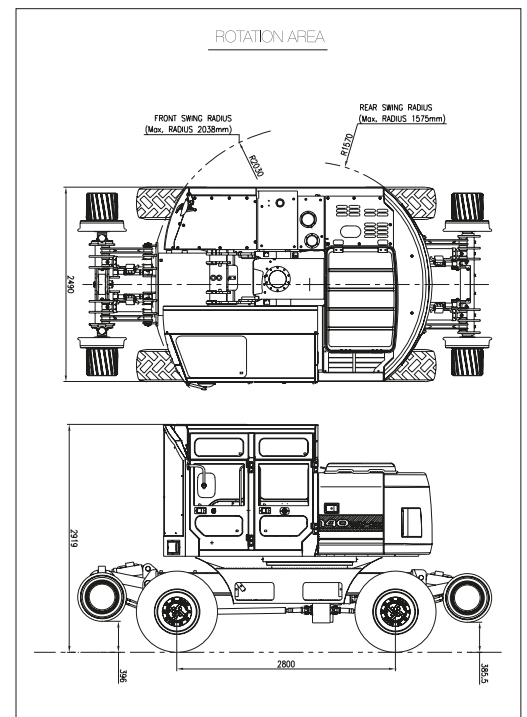

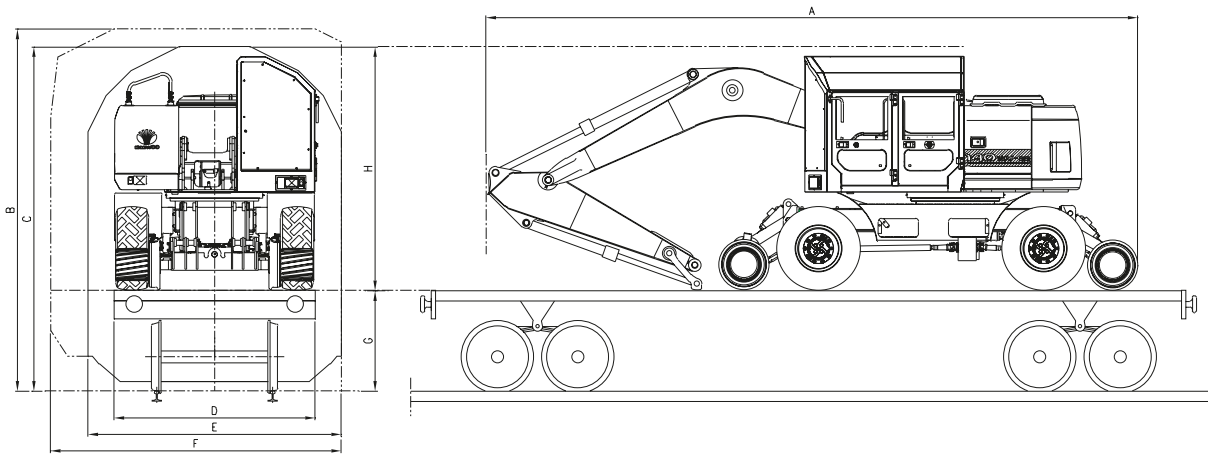

Dimensions

Overall Length	A	mm	8.100
Security shape overall height	B	mm	4.500
Transportation shape overall height	C	mm	4.280
Rail way carriage length	D	mm	2.500
Transportation shape length	E	mm	3.150
Security shape length	F	mm	3.613
Rail way carriage height	G	mm	1.250
Overall height	H	mm	3.020

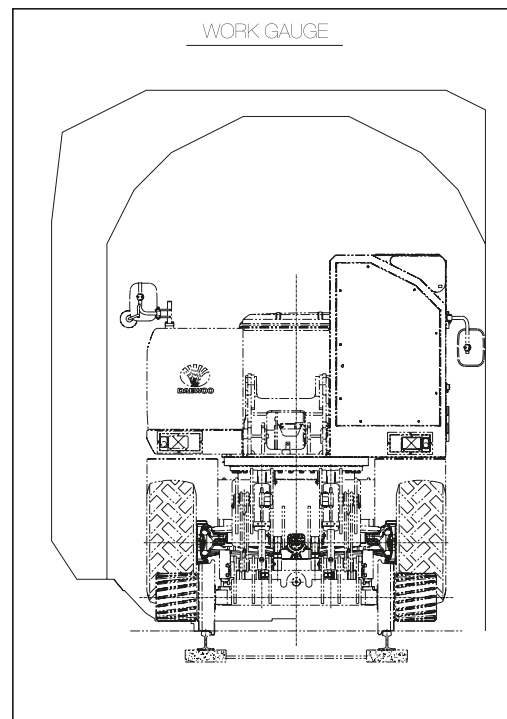

Operational data

DIGGING FRONT WORKING RANGES

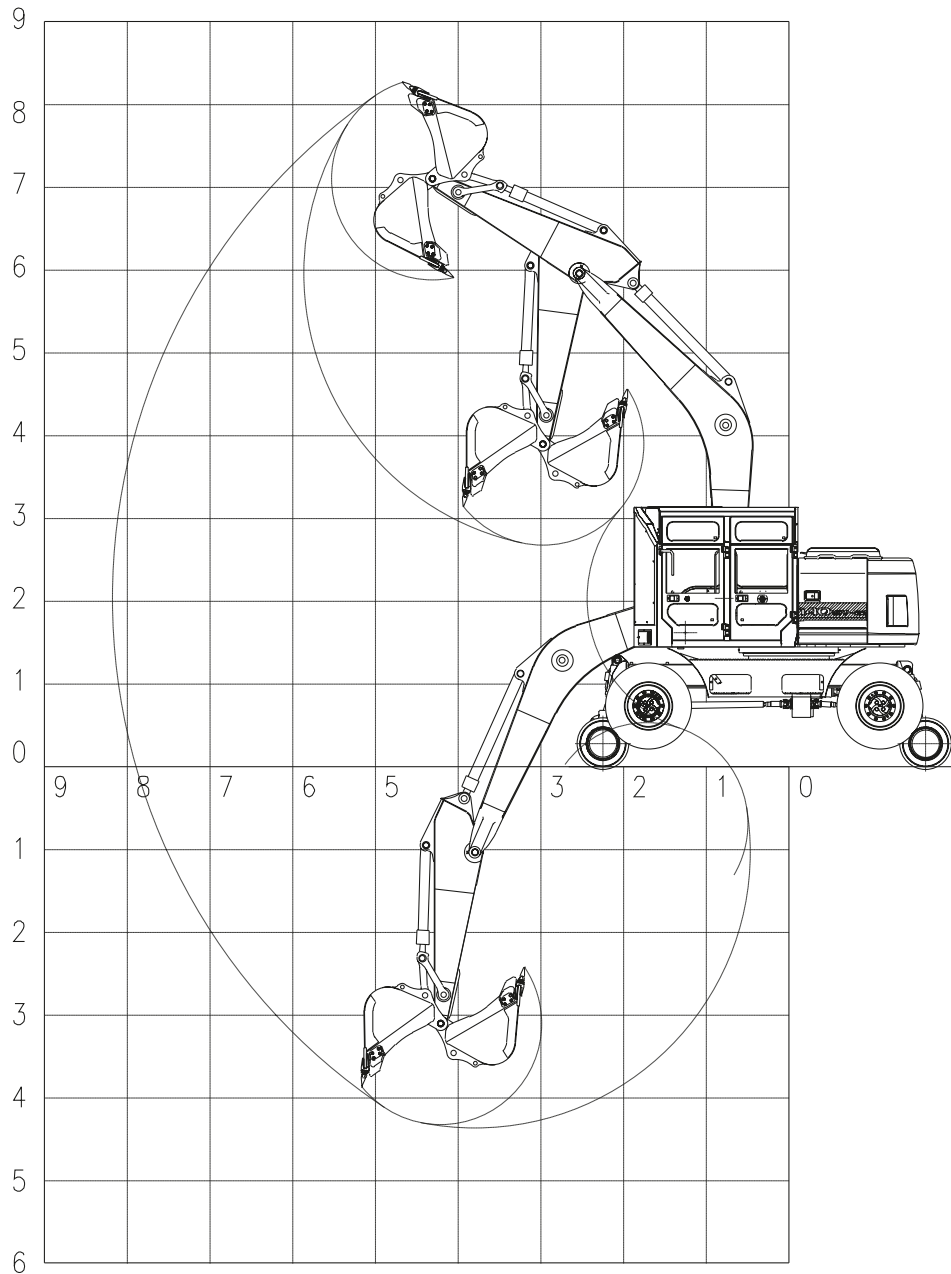

Lifting Capacities

Boom : 4,3 m

Arm : 2,1 m

Weight : 18,27 ton

F= Rating over to center of rail road

S= Rating over to perpendicular of center of rail road

Rating on Michelin tyres (XZL368 / 85R20)

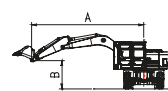
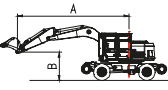
A(m)	3,5		4		5		6		7		
	F	S	F	S	F	S	F	S	F	S	
B(m)											
3	5,80	2,70	5,52	2,60	4,41	2,25	3,63	1,94			S 
2			5,49	2,05	4,38	1,57	3,61	1,26	2,66	0,95	F 

Rating on excavator rail aid without banking

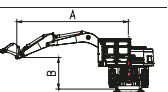
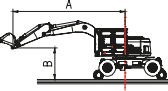
A(m)	3,5		4		5		6		7		
	F	S	F	S	F	S	F	S	F	S	
B(m)											
3	5,80	2,20	5,52	2,10	4,41	1,52	3,63	1,17			S 
2			5,49	1,95	4,38	1,42	3,60	1,13	2,66	1,12	F 

Rating on excavator rail aid with banking

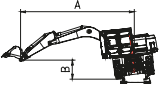
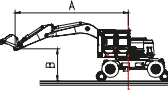
A(m)	3,5		4		5		6		7		
	Dévers	S	F	S	F	S	F	S	F	S	
B(m)											
2,5	180 mm	1.55	5.27	1.48	4.15	1.38	3.40	1.18	2.57	0.88	S 
2,5	135 mm	1.62	5.35	1.54	4.30	1.44	3.47	1.23	2.60	0.91	
2,5	90 mm	1.92	5.46	1.74	4.38	1.65	3.59	1.29	2.64	1.11	F 
2,5	45 mm	2.00	5.52	1.80	4.42	1.70	3.63	1.32	2.68	1.15	

Machine on horizontal and dense ground or front rail aid jamed

Complete rotation of upper structure is allowed

Rating are based on SAE J1097

Rated loads do not exceed 87% of hydraulic capacity or 75% of tipping capacity

Seoul Office

9th Floor, Daewoo Heavy Industries & Machinery Ltd. Bldg.
14-34, Youido-dong, Youngdungpo-gu
150-010, Seoul Korea
Mail: C. P. O Box 7955 Seoul, Korea
Tel. +82 2 2167-3114 Fax +82 2 785-2677
Website: www.dhiltltd. co. kr

Euro Daewoo S. A.

1A Rue Achille Degrâce,
7080 Frameries, Belgium
Tel. +32 65 61 32 30 Fax +32 65 67 73 38

Euro Daewoo France

2/4, Rue Pavlov, Z.I. des Bruyères
78190 Trappes, France
Tel. +33 1 30 16 21 41 Fax +33 1 30 16 21 44

Euro Daewoo UK

Daewoo House Unit 6.3 Nantgarw Park Cardiff
CF4 7QU, U.K.
Tel. +44 1443 842273 Fax +44 1443 841933

Daewoo Maschinen Vertriebs GmbH

Hans-Böckler-Str. 27-29
40764 Langenfeld, Germany
Tel. +49 2173 8509 18 Fax +49 2173 8509 45
Website: www.daewoobaumaschinen.de



The illustrations do not necessarily show the product in standard version. All products and equipments are not available in all markets.
Materials and specifications are subjects to change without prior notice.